

## FACTORY ALARM DISARM (NEGATIVE THROUGH RESISTOR)

► Use relays to interface with the factory arm/disarm wire. Wire as shown:

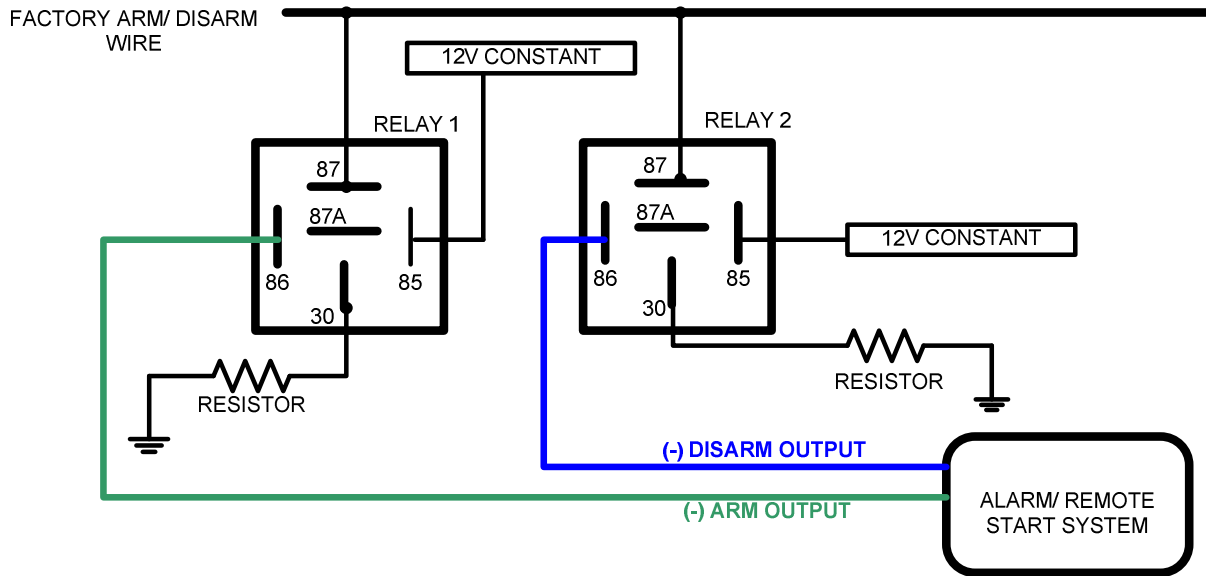

### RELAY 1

PIN	CONNECTION
85	TO 12V CONSTANT
86	TO (-) ARM OUTPUT FROM ALARM/REMOTE START SYSTEM
87	TO ARM/DISARM WIRE IN VEHICLE
87A	NO CONNECTION
30	TO CHASSIS GROUND THROUGH A RESISTOR

### RELAY 2

PIN	CONNECTION
85	TO 12V CONSTANT
86	TO (-) DISARM OUTPUT FROM ALARM/REMOTE START SYSTEM
87	TO ARM/DISARM WIRE IN VEHICLE
87A	NO CONNECTION
30	TO CHASSIS GROUND THROUGH A RESISTOR

Remote starter and security installations should be attempted by experienced security installers only. Information contained is accurate to the best of our knowledge and experience. Information contained is without any representation of warranty. It is the installer's responsibility to test and confirm all circuits with a digital multi-meter. Proper installation remains the responsibility of the installer. CarInstallExperts.com assumes no liability or responsibility resulting from an improper installation, even in reliance with the information contained in this guide.